

FAST TRACK™ 8800

8870 Series Servohydraulic Testing Systems

Flexible and Compact Servohydraulic Testing Solutions



*The difference
is measurable™*

8870 Series – Flexible and Compact Servohydraulic Testing Solutions

The Instron® 8870 series of servohydraulic testing systems have been developed to meet the challenging demands of a varied range of both static and dynamic testing requirements. The flexibility offered within the 8870 family provides complete testing solutions to satisfy the needs of advanced materials, biomedical and component testing. The compact design of the 8870 frames make them ideal for installation within any laboratory environment, either on an existing bench, or with its own purpose designed support frame.

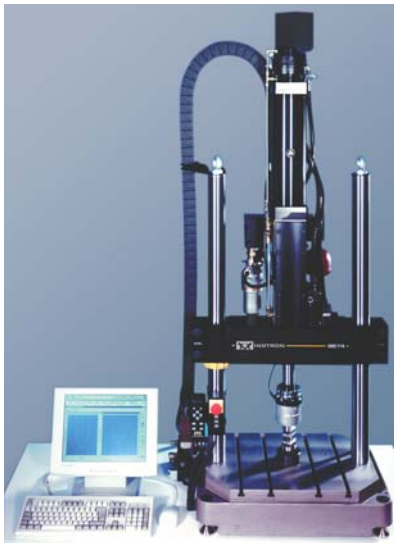

▲ Instron 8874 axial-torsion servohydraulic test system

Axial or Biaxial Capability

The 8870 family encompasses the following model variants:

- 8871: Axial-only. Maximum load capacities of ± 5 kN (± 1.1 kip) and ± 10 kN (± 2.2 kip).
- 8872: Axial-only. Maximum load capacities of ± 10 kN (± 2.2 kip) and ± 25 kN (± 5.6 kip).
- 8874: Axial-torsion. Maximum load capacities of ± 10 kN (± 2.2 kip) and ± 25 kN (± 5.6 kip). Torsional capacity of ± 100 Nm (± 880 in-lb).

The 8871 is supplied with a 103-bar (1500 psi) hydraulic power unit, while the 8872 and 8874 require the addition of a 207-bar (3000 psi) hydraulic power unit.



▲ 8872 machine

Patented Integral Inertia Compensation

During dynamic testing, particularly when the load cell is mounted on the actuator as required by many component or biomedical test applications, inertial load can be generated due to the acceleration of the grip or fixture. The patented Dynacell™, fitted as standard to the 8870 series, automatically compensates for this, providing accurate and repeatable test data you can rely on.

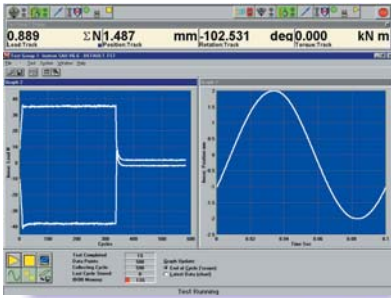

▲ MAX™ software displaying the effectiveness of Instron's Dynacell. The graph on the left of the screen shows the reduction in load (maximum and minimum) when the inertia compensation is activated.

The machine was running a position amplitude of 2 mm at 10 Hz with no specimen. A compression platen with a mass of 2 kg was fitted to the end of the loadcell, which was in turn fitted to the end of the actuator.

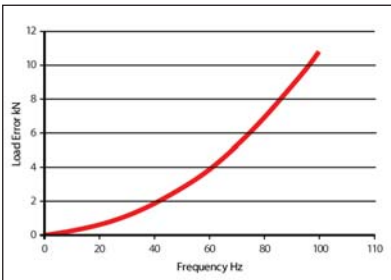

▲ Load error in a conventional load cell as a result of acceleration effects. The graph shows the measured load error as a function of test frequency for an amplitude of 1 mm on a machine fitted with 100 kN grips. Instron's Dynacell virtually eliminates this error.

Test Space to Suit Your Application

The standard vertical test space is suitable for most test requirements. However, for applications requiring additional space, for example, when using an environmental chamber, extended height frames are available.

Integral T-Slot Base

To accommodate the needs of many biomedical and component testing applications, the 8870 series feature a unique T-slot base as standard. The base is electroless nickel-plated to protect against corrosion in wet test environments such as saline or serum. A built-in drain feature allows spilled fluid to be drained from the base channels.



▲ Environmental chamber mounted on an extended height 8872 machine

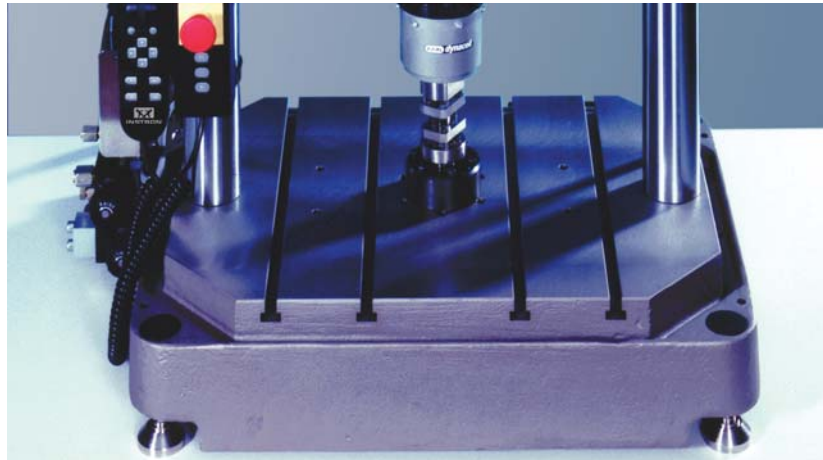

▲ Unique T-slot base is a standard feature of the 8870 series

8870 Series – Configured to Meet Your Test Demands

A wide range of system options, grips, fixtures and accessories allow the 8870 series to be customised for specific applications. Whether your application demands low or high temperatures, fluid immersion, or complex specimen gripping geometry, Instron® offers a complete tailored solution.

Low Force Dynamic and Static Testing

In addition to the standard Dynacell™ supplied with the system, Instron offers a range of lower capacity Dynacells for low force test requirements such as soft tissue testing. Featuring the same high levels of accuracy and repeatability as every Instron load cell, they also feature the unique inertia compensation feature as standard. A range of lightweight grips and fixtures are also available.

High Performance Systems

Where a high level of dynamic performance is required, either large amplitudes, high frequencies, or a combination of both, the 8872 frame can be specified with dual servovalves in place of the standard single servovalve configuration.

Actuator Bearing Options

The 8872 model features two actuator bearing options. The standard labyrinth bearings are suitable for general testing. For applications where superior actuator guidance or side loading resistance are required, Instron's unique hydrostatic bearing actuators are also available. The 8874 axial-torsional model features hydrostatic bearings as standard.

Wide Range of Grips, Fixtures and Accessories

Whether your application requires static tensile grips, hydraulic grips for reverse stress testing, bend fixtures, environmental chambers or saline baths, there is an Instron accessory to suit.

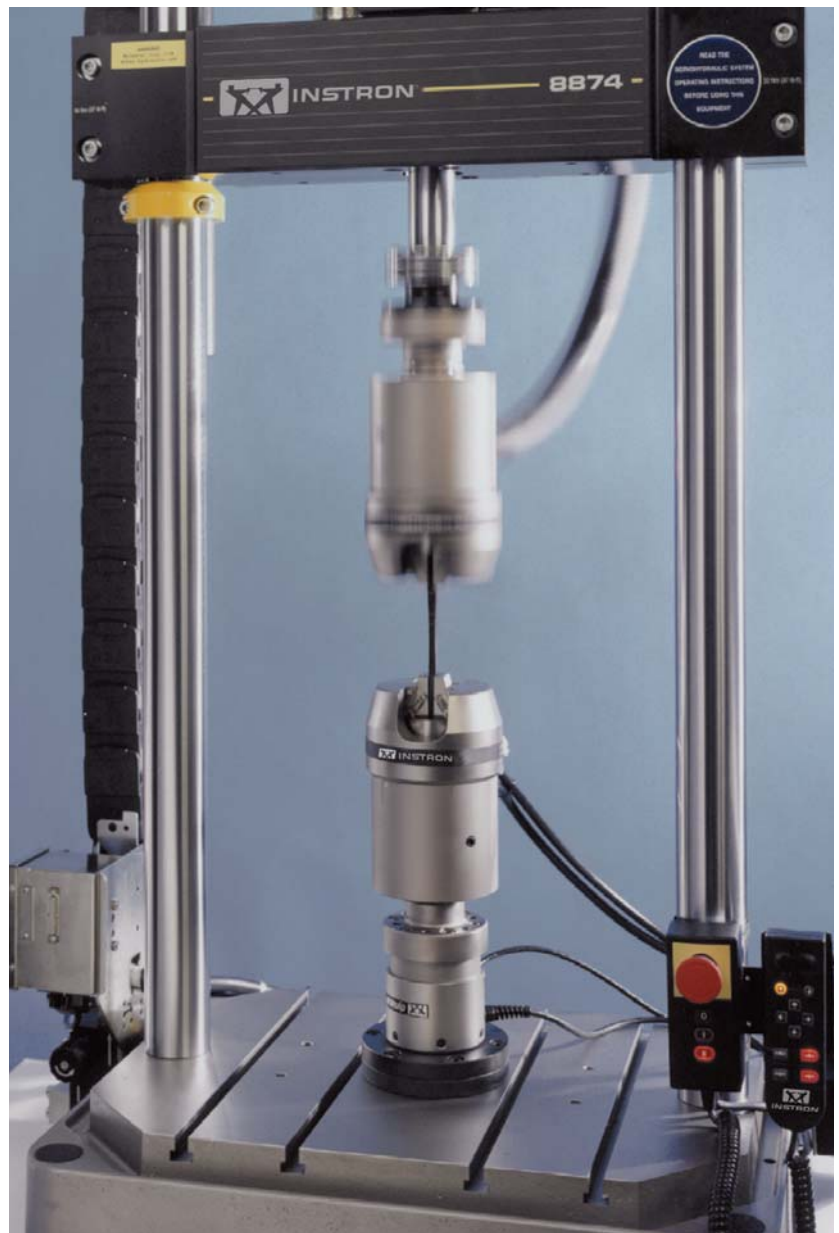

▲ Hydraulically operated wedge grips for static and dynamic axial-torsional applications

Choice of Controller and User Interface for Your Application and Your Budget

At the heart of the 8870 system is the FastTrack™ 8800 controller. With features such as Instron®'s patented adaptive control technology, 19-bit resolution across the full range of the transducers, automatic loop tuning, and amplitude control, the FastTrack 8800 offers unsurpassed precision, repeatability and data integrity. The FastTrack 8800 is available in three variants; the 8800LT, the 8800 desktop, and the 8800 tower.

The choice of user interfaces include stand-alone hard panels and the flexible Windows® based FastTrack console software interface.

Fully Flexible Software Helps You Accomplish More With Less

The FastTrack applications suite covers a broad spectrum of testing requirements. It includes flexible programs for general purpose testing, turnkey programs for specific applications, and tools for developing your own programs.



▲ The FastTrack 8800 has a choice of user interfaces

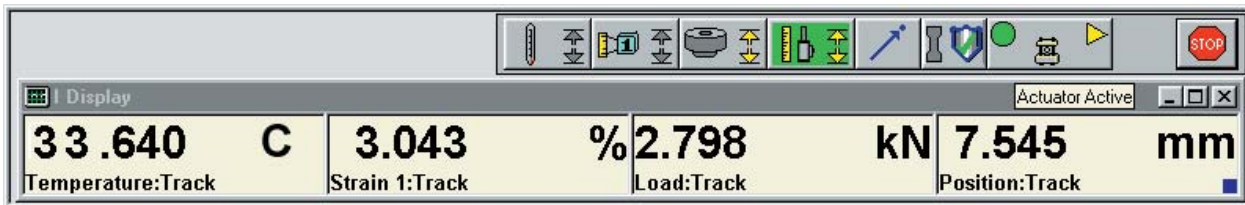

Built on a Common Platform

The FastTrack 8800 family of controllers are state of the art fully digital servohydraulic controllers which utilise core technologies. When configuring the system, you simply select the best value package to suit your application; 8800LT, desktop or a tower.

Note: Instron 8874 only available with FastTrack 8800 tower controller.



Ideally Suited to a Wide Variety of Applications

There are hundreds of 8870 series systems installed worldwide. At work in a diverse spread of industries, from medical research to aerospace, they are put to use in an huge range of applications.

Hip Simulation

Wear of Total Hip Replacements (THR) has been identified as one of the major causes of osteolysis and consequently implant failure. The Biopuls™ Dual-Station™ ISO and ASTM hip simulators were designed to address the more demanding requirements of the ISO 14242 and ASTM F 1714 standards. The hip simulators can be offered as an accessory for 8870 test systems, providing a unique approach for hip wear testing.

The 8874 is a versatile test system that in addition to the long-term wear simulation tests, can be easily reconfigured to accommodate a full range of other biomechanical tests.

High Temperature Testing of Automotive Engine Compartment Components

Components within the engine compartment of a vehicle must be able to withstand extremes of temperature in service. High temperatures are experienced when the engine is at operating temperature, and very low temperatures when a vehicle is standing overnight in cold climates. Furthermore, due to the operating environment of these components, they are also subject to cyclic fatigue caused by vibration and cyclic loading in use. A global OEM supplier to the automotive industry puts their components to the test using an Instron® 8872 testing system fitted with an Instron 3119 series environmental chamber. Using the advanced capability of the FastTrack™ 8800 controller, the user can synchronise cyclic loading with changing temperature profiles to accurately simulate the service environment of the component, ensuring that next time you take a long drive, you won't be left stranded.

Skin Tissue Testing in Simulated In-Vivo Environments

Biomedical engineered materials are being developed at a rapid pace in an increasingly competitive market. These materials require special testing within controlled environments that simulate the human body. The most common application is to test skin tissue and tissue-like materials in a saline solution at human body temperature.

An Instron® 8870 system fitted with a temperature controlled saline bath can be used to test the strength of sutures used in tissue repair. The bath uses a recirculating system to ensure the sample is kept at body temperature, while the Dynacell™'s integral inertia compensation feature compensates for load errors introduced due to drag on the grips from the saline solution.



▲ Biopuls Dual-Station ISO hip simulator on an 8874 system



▲ An engine mount is tested on an Instron 8872 machine

Specifications

Model Number	8871	8872	8874
(D) MAXIMUM DAYLIGHT:			
(D1) LOAD CELL, ACTUATOR MOUNTED			
Standard Height	767 mm (30.2 in)	767 mm (30.2 in)	733 mm (28.86 in)
Extra Height	1067 mm (42 in)	1067 mm (42 in)	1033 mm (40.67 in)
(D2) LOAD CELL, TABLE MOUNTED			
Standard Height	758 mm (29.84 in)	758 mm (29.84 in)	701 mm (27.6 in)
Extra Height	1058 mm (41.65 in)	1058 mm (41.65 in)	1001 mm (39.4 in)
(E) Column Spacing	455 mm (17.91 in)	455 mm (17.91 in)	455 mm (17.91 in)
(F) Column Diameter	65 mm (2.56 in)	65 mm (2.56 in)	65 mm (2.56 in)
(G) COLUMN LENGTH			
Standard Height	1070 mm (42.13 in)	1070 mm (42.13 in)	1070 mm (42.13 in)
Extra Height	1370 mm (53.94 in)	1370 mm (53.94 in)	1370 mm (53.94 in)
(H) Table Width	667 mm (26.26 in)	667 mm (26.26 in)	667 mm (26.26 in)
(I) Table Height	135 mm (5.31 in)	135 mm (5.31 in)	135 mm (5.31 in)
(J) Feet Height (Minimum) Adjustable	22 mm (0.87 in)	22 mm (0.87 in)	22 mm (0.87 in)
(K) Overall Width	815 mm (32.1 in)	815 mm (32.1 in)	815 mm (32.1 in)
(L) Overall Depth	483 mm (19.01 in)	483 mm (19.01 in)	483 mm (19.01 in)
(M) OVERALL HEIGHT (MAXIMUM)			
Standard Height	2014 mm (79.3 in)	2014 mm (79.3 in)	2359 mm (92.87 in)
Extra Height	2331 mm (91.77 in)	2331 mm (91.77 in)	2659 mm (104.69 in)
WEIGHT			
Standard Height	260 kg (573 lb)	260 kg (573 lb)	300 kg (661 lb)
Extra Height	287 kg (632 lb)	287 kg (632 lb)	327 kg (720 lb)

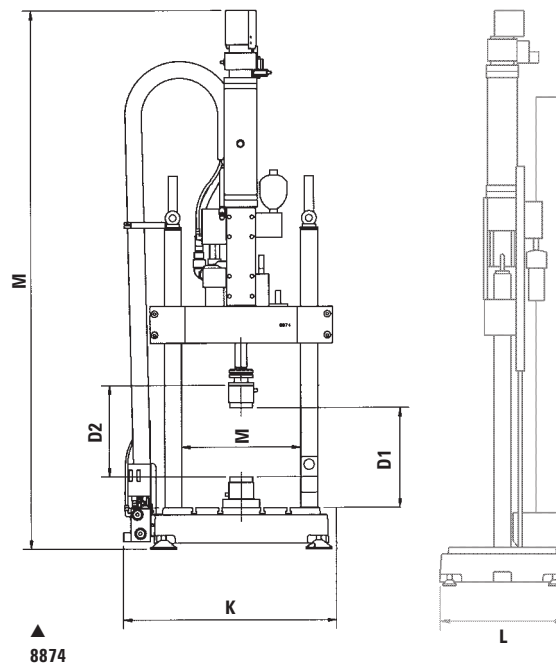
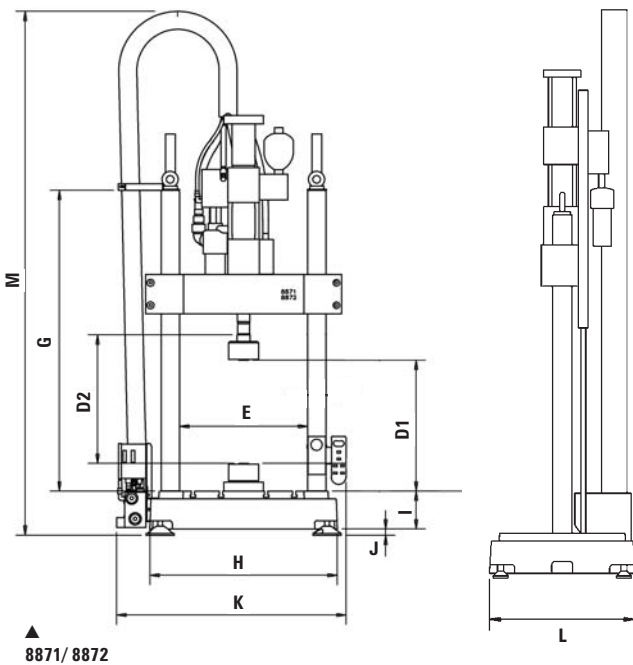

EXTEND™ Upgrade Systems

Experience the benefits of the FastTrack™ 8800 systems on your existing load frames with an Instron® EXTEND upgrade system.

At Instron we are experts in upgrading material test systems. Through our EXTEND packages, we upgrade Instron and non-Instron load frames with the latest digital electronics and application software. The result is a superior system at a fraction of the cost of a new machine.

Instron has upgraded more test equipment than anyone in the industry - more than 5,000 systems and still counting. An Instron upgrade ensures your test system will be outfitted with the industry's most advanced software and electronics. Furthermore, your investment will be supported by Instron's worldwide network of experienced service engineers.



▲ Non-Instron frames that have been upgraded with FastTrack 8800 controllers



For information on Instron products and services call your local worldwide sales, service and technical support offices:

Corporate Headquarters

Instron Corporation
825 University Ave
Norwood, MA 02062-2643 USA
Tel: +1 800 564 8378
+1 781 575 5000
Fax: +1 781 575 5751

European Headquarters

Instron Limited
Coronation Road
High Wycombe, Bucks
HP12 3SY United Kingdom
Tel: +44 1494 464646
Fax: +44 1494 456814

Industrial Products Group

900 Liberty Street
Grove City, PA 16127-9005 USA
Tel: +1 800 726 8378
+1 724 458 9610
Fax: +1 724 458 9614

USA

North America IMT Sales and Service Center

Sales Tel: +1 800 564 8378
Service and Technical Support Tel: +1 800 473 7838

North America IST Sales and Service Center

Sales and Service Tel: +1 248 553 4630

CANADA

Toronto Tel: +1 905 333 9123
+1 800 461 9123

SOUTH AMERICA, CENTRAL AMERICA, MEXICO AND CARIBBEAN

Brazil

Sao Paulo Tel: +55 11 4195 8160

Caribbean, Mexico, South America and Central America

Canton Tel: +1 781 821 2770

EUROPE

United Kingdom, Ireland, Sweden, Norway and Finland

High Wycombe Tel: +44 1494 456815

Benelux and Denmark

Edegem Tel: +32 3 454 0304

France

Paris Tel: +33 1 39 30 66 30

Germany and Austria

Darmstadt Tel: +49 6151 3917 444

Italy

Milan Tel: +39 02 390 9101

Spain and Portugal

Barcelona Tel: +34 93 594 7560

ASIA

China

Beijing Tel: +86 10 6849 8102
Shanghai Tel: +86 21 6215 8568

India

Chennai Tel: +91 44 2 829 3888

Japan

Tokyo Tel: +81 44 853 8520

Osaka

Tel: +81 6 6380 0306

Nagoya

Tel: +81 52 201 4541

Korea

Seoul Tel: +82 2 552 2311/5

Singapore

Tel: +65 6774 3188

Taiwan

Hsinchu Tel: +886 35 722 155/6

Thailand

Bangkok Tel: +66 2 513 8751

AUSTRALIA

Melbourne Tel: +61 3 9720 3477



Instron is a registered trademark of Instron Corporation.

Other names, logos, icons and marks identifying Instron products and services referenced herein are trademarks of Instron Corporation and may not be used without the prior written permission of Instron.

Other product and company names listed are trademarks or trade names of their respective companies.

Copyright © 2005 Instron Corporation. All rights reserved.

All of the specifications shown in this brochure are subject to change without notice.

www.instron.com

WB1104C